

MODEL 5514S
OSCILLOSCOPE
INSTRUCTION MANUAL

KIKUSUI ELECTRONICS CORP.

78,8,31

782154

Power Requirements of this Product

Power requirements of this product have been changed and the relevant sections of the Operation Manual should be revised accordingly.

(Revision should be applied to items indicated by a check mark)

Input voltage

The input voltage of this product is _____ VAC,
and the voltage range is _____ to _____ VAC. Use the product within this range only.

Input fuse

The rating of this product's input fuse is _____ A, _____ VAC, and _____.

WARNING

- To avoid electrical shock, always disconnect the AC power cable or turn off the switch on the switchboard before attempting to check or replace the fuse.
- Use a fuse element having a shape, rating, and characteristics suitable for this product. The use of a fuse with a different rating or one that short circuits the fuse holder may result in fire, electric shock, or irreparable damage.

AC power cable

The product is provided with AC power cables described below. If the cable has no power plug, attach a power plug or crimp-style terminals to the cable in accordance with the wire colors specified in the drawing.

WARNING

- The attachment of a power plug or crimp-style terminals must be carried out by qualified personnel.

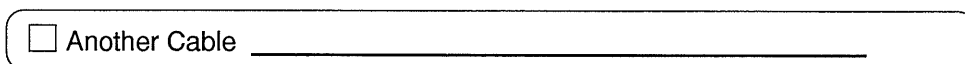
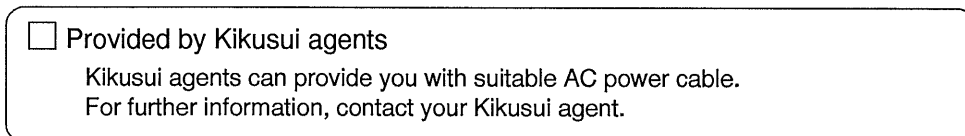
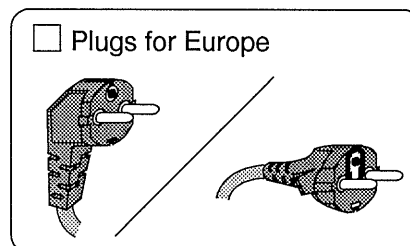
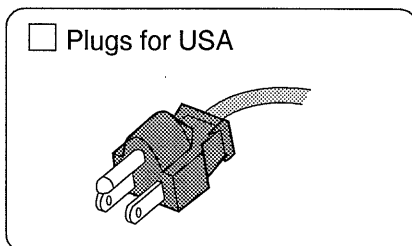
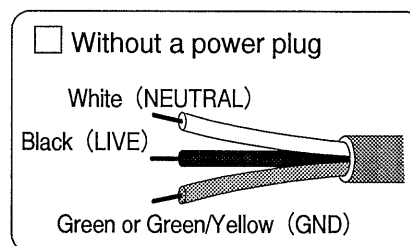
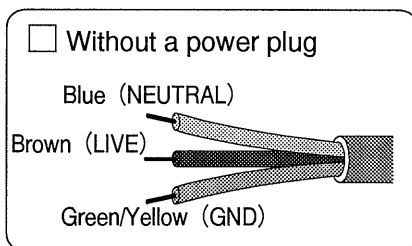

CONTENTS

1.	GENERAL	1
1.1	General	1
1.2	Features	1
2.	SPECIFICATIONS	3
3.	EXPLANATION ABOUT FUNCTIONS	7
3.1	Explanation of front panel	7
3.2	Explanation of rear panel	11
3.3	Explanation of bottom panel	11
3.4	Caution of operation	15
3.5	Change of Line Voltage	16
4.	OPERATION	17
4.1	Initial operation	17
4.2	Dual channel mode operation	19
4.3	X-Y mode operation	20
4.4	External intensity modulation (INTEN MOD)	20
4.5	Sweep magnification	21
4.6	Operation of the TRIG MODE	22
5.	MEASUREMENT	23
5.1	Application Method of Vertical Input Signal	23
5.2	Voltage Measurement	26
5.3	Current Measurement	26
5.4	Time Interval Measurement	27
5.5	Frequency Measurement	27
5.6	Phase difference Measurement	28
5.7	Pulse Waveform Measurement	30
6.	CALIBRATION	32
6.1	General	32
6.2	Check of DC Power Supply and Adjustment of High Voltage Power Supply	32
6.3	Adjustment of Vertical Axes	34
6.4	Adjustment of Time Base	35
6.5	Adjustment of Horizontal Axis (X axis)	36
6.6	Adjustment of CRT circuit	36
6.7	Calibration of Probe	38
7.	Block Diagram	39

1. GENERAL

1.1 General

The Model 5514S is a portable dual channel triggered oscilloscope, which employs a 133mm round high bright CRT with low distortion. The vertical amplifiers have a high sensitivity of 5mV/DIV and cover a wide frequency range of DC to 15 MHz and can be multiplied by factor of 5. Both channels are obtained high-sensitivity of 1mV/DIV at 5MHz frequency range. The maximum sweep speed is 100ns/DIV (When the sweep magnification is affected.).

The Model 5514S can widely be used not only for production line, maintenance and service, but also for research and development of electronic equipments. Main features are explained as follows :

1.2 Features

* Controllability

The Model 5514S provides an excellent controllability by the use of pushbutton switches and rotary switches with low rotation torque, and locations of knobs which fit to operating frequency.

* Use of ICs and controls by DC signals

ICs are widely employed. Vertical axis has high performance characteristics of a high sensitivity, low drift and excellent reliability, as variable gain controls, operation mode selector and so on are controlled by DC signals, and dual FETs are employed in vertical pre-amplifier circuits.

* Employ of a high brightness CRT.

A fully bright trace is displayed on high speed sweep.

* High voltage source is regulated by DC to DC convertor

A high voltage power supply is regulated by DC to DC convertor. Measurement can be made without effects of change of supply line voltage and so on.

* Employment of a trace rotation coil

Horizontal incline of a trace by terrestrial magnetism is easily adjusted by means of employing of a trace rotation coil.

* Attachment for camera and scale illumination

An essential attachment for camera can easily be attached to bezel by an action, and brightness of the scale illumination is variable. Superior photographs of displayed waveform are obtained for this function.

- * Switching between CHOP mode and ALT mode is automatically made. Troublesome switching between CHOP mode and ALT mode is automatically made with setting of sweep time, for it is linked with the TIME/DIV switch.
- * Trigger signal is easily selected.
When the TRIGGERING selector is set in the INT position, triggering is linked with the vertical MODE selector, and made by displayed waveform on the CRT screen.
- * Synchronization in TV video signal
Synchronizing separator circuit is automatically switched in vertical (TV.V) or horizontal (TV.H) synchronizing circuit with setting of the TIME/DIV switch, it is linked with the TIME/DIV switch.
- * X-Y mode is selected with an action.
The Model 5514S operates as a X-Y oscilloscope by switching the MODE selector in the X-Y mode. CH1 input is operated as X axis input, and CH2 is operated as Y axis input, and another operation mode is available which employs an independent EXT HORIZ IN (X-axis) input. This can be done by switching and the LEVEL knob should be pulled out. The knob is for continuously variable adjustment of gain.
CH1 and CH2 are operated as Y axis input, and EXT HORIZ IN is operated as X axis input.
- * Maximum sweep speed of 100ns/DIV (5XMAG)
Sweep time can be multiplied by a factor of 5.
Although maximum sweep speed without effect of sweep magnification is 0.5 μ s/DIV, that of 100ns/DIV is obtained with effected of sweep magnification.

2. SPECIFICATIONS

CRT

Item	Specifications	Remarks
Type	133mm round	
Fluorescent material	B31	Green
Acceleration voltage	Approximately 1600 V	
Effective screen size	10 DIV X 8 DIV	1 DIV = 9.5 mm
Unblanking	DC coupling	
Illumination	Scale brightness is continuously adjustable	

Vertical Deflection

Item	Specifications	Remarks
Sensitivity	5mV/DIV ~ 10V/DIV 1mV/DIV ~ 2V/DIV (for 5xMAG)	1, 2, 5 steps
Sensitivity accuracy	Within $\pm 3\%$ of panel indicated value, with VARIABLE knob in CAL'D position. Within $\pm 5\%$ for 5x MAG.	Accuracy within $\pm 3\%$ is satisfied for measurement of 8 DIV single amplitude. each ranges.
Sensitivity continuously variable	Continuously variable between panel indicated values.	
Frequency bandwidth	DC : DC ~ 15 MHz (DC ~ 5MHz for 5x MAG) AC : 2Hz ~ 15 MHz (2Hz ~ 5 MHz for 5x MAG)	Within -3dB 50kHz, 8 DIV reference
Rise time	Approximately 23.3 ns	Approx. 70ns for 5xMAG
Input impedance	1 M Ω $\pm 2\%$, 30pF $\pm 2\text{pF}$	
Input terminals	BNC receptacles	
Maximum allowable input voltage	400V at 5mV, 10mV and 20mV ranges. 600V at other ranges.	DC-AC peak value 1kHz or below
Input coupling	AC and DC	
Shift of base line caused by range switching	Less than ± 0.5 DIV for switching range. ± 2.0 DIV for 5x MAG	Shift of DC balance is included.
Operation modes of vertical axes	CH1	CH1 only
	CH2	CH2 only
	DUAL	CHOP ALT (Linked with TIME/DIV SWITCH.)
Switching frequency	CH1 and CH2 are switched at approximately 200kHz.	
Linearity	When 4 DIV signal displayed in the CRT center is fully moved in effective vertical area, variation amplitude of the signal is within ± 0.2 DIV.	For signal frequency of less than 100kHz, including CRT linearity.

Triggering

Item	Specifications		Remarks
Trigger modes	NORM	The circuit is at stand-by state, when the circuit is not triggered. Traces are extinguished.	Specification of the trigger sensitivity is satisfied.
	AUTO	The circuit free runs, when the circuit is not triggered.	The trigger sensitivity specification is satisfied for signals of 50Hz and over.
	TV	Synchronizing separator circuit is connected to the trigger circuit	The circuit is set in TV.V for 0.5s~0.1ms and in TV.H for 50 μ s ~ 0.5 μ s.
Trigger source	INT	When the MODE selector is set in the CH1 and/or the CH2, the signals for displayed traces, are used as trigger signal source. When the MODE selector is set in the DUAL, the signal for CH1 is used as trigger signal source.	
	EXT	Input signal to the EXT TRIG terminal is used as a trigger signal source.	
Internal trigger sensitivity			
DC	DC ~ 10 MHz	0.5 DIV	
AC	DC ~ 15 MHz	1.0 DIV	
TV	2 Hz ~ 10 MHz	0.5 DIV	
External trigger sensitivity	2 Hz ~ 15 MHz	1.0 DIV	
DC	Video signal amplitude	1.0 DIV	
AC	DC ~ 15 MHz	0.5 V	
TV	2 Hz ~ 15 MHz	0.5 V	
TV	Video signal	1.0 V	
Polarity	+ and -		
Coupling	AC and DC		
External trigger input impedance	Approximately 1 M Ω , 50pF or below		
Maximum allowable input voltage	100Vp-p (DC + AC peak)		1 kHz or below
External input terminal	BNC receptacles		Used in common for EXT HORIZ IN terminal.

Horizontal deflection

Item	Specifications	Remarks
Sweep time	0.5 μ s/DIV ~ 0.5s/DIV	1.2.5 steps
Sweep time continuously variable range	Adjustable by 2.5 times or over of panel indicated value.	
Sweep magnification	5 times	
Magnification error	Within $\pm 5\%$	
Position shift caused by magnification	Within ± 1 DIV at CRT screen center.	
X-Y operation	CH1 : X X is horizontal axis CH2 : Y Y is vertical axis	
Sensitivity	Same value as CH1 of vertical deflection	
Frequency bandwidth	DC: DC ~ 1 MHz AC: 2 Hz ~ 1 MHz	Within -3dB, 50kHz 8 DIV reference
Input impedance	Same value as CH1 of vertical deflection	
Maximum allowable input voltage	Same value as CH1 of vertical deflection	
X-Y phase difference	Within 3° at 50 kHz	

External Horiz In Sensitivity	200mV/DIV or over 40mV/DIV or over, for 5 MAG	
Frequency bandwidth	DC ~ 500kHz, within -3dB (GAIN VAR. at MAX. position)	50kHz 10DIV reference
Gain variable range	Continuously variable	10 times or over
Input impedance	Approx. 100k Ω , 50pF	
Maximum allowable input voltage	100Vp-p (DC+ACpeak)	Freq. not higher than 1kHz
Phase difference between Y and X axis	Within 3° at 10kHz	
Input terminal	BNC receptacle	Used in common for EXT TRIG IN terminal

Z axis

Item	Specifications	Remarks
Sensitivity	Modulation is visible for input of 3Vp-p or over	
Frequency	DC ~ 5 MHz	
Polarity	Trace is darkened with positive input and brightened with negative input.	
Input resistance	Approximately 10 k Ω	
Input terminals	Binding-posts	

Calibration Voltage

Item	Specifications	Remarks
Waveform	Positive going square waveform	
Output voltage	1 Vp-p \pm 3%	
Frequency	1 kHz \pm 25%	
Duty ratio	45:55 ~ 55:45	
Output terminal	Chip terminal	

Power Supply

Item	Specifications	Remarks
Supply line voltage	100V, 110V, 120V, 220V, 230V and 240V Within \pm 10% of each value.	Changed by taps of a power transformer.
Frequency	50Hz ~ 60Hz	
Power consumption	Approximately 30 VA	

Mechanical Specification

Item	Specifications	Remarks
Dimensions	242W x 184H x 370D mm	
	250W x 210H x 435D mm	Maximum
Weight	Approximately 8 kg	

Accessories

Item	Specifications	Quantity
Instruction manual		1

Ambient Temperature and Humidity

Operating temperature & humidity range	5 ~ 35°C, less than 85% R.H.	
	0 ~ 40°C, less than 90% R.H.	(Maximum)







3. EXPLANATION ABOUT FUNCTIONS

3.1 Explanation of front panel (Refer to Fig. 1)

No.	Characters of panel	Explanation
①	ILLUM POWER OFF	This knob is used in common for both power on-off control and scale illumination control. The extremely counterclockwise position is the power-off position. When turning it clockwise, the power turns on and brightness of graticule lines of the CRT screen is controlled.
②	INTEN	Trace intensity control. Brightness of spot or trace displayed on the CRT screen is controlled by this knob.
③	FOCUS	Focus control. This knob is adjusted so that the spot or trace displayed on the CRT screen is most well-defined.
④	CALIBRATOR 1 Vp-p	Terminal for calibrator output. It is used for sensitivity calibration and probe phase adjustment, and provides a square wave of an approximately 1 kHz and 1 Vp-p.
⑤	$\frac{1}{\text{---}}$	GND terminal.
⑥	—	Scale plate. Brightness of graticule lines is adjustable by this knob.
⑦	—	Bezel to which attachment for photography can be mounted by an action.
⑧	↑ POSITION ↓ PULL 5 × MAG	Vertical position control for CH2 (or Y axis). The spot or trace displayed shifts downwards with counterclockwise turning, and upwards with clockwise turning. When knob is pulled out, sensitivity is multiplied by a factor 5.
⑨ ⑩ ⑪ ⑫	MODE CH1.....⑫ DUAL....⑪ (CH1 TRIG) X-Y.....⑩ CH2⑨	Interlocked pushbutton switch with 4 sections which switch selects the operation modes of CH1 and CH2, and trigger signal source. CH1: The oscilloscope operates as a single channel instrument. Input signal to CH1 operates as a trigger signal source. CH2: The oscilloscope operates as a signal channel instrument. Input signal to CH2 is used as a trigger signal source. DUAL: As vertical amplifiers of CH1 and CH2 are switched in the CHOP and ALT mode, the instrument operates as a dual channel oscilloscope. Input signal to CH1 is used as a trigger signal source. (Switching between the CHOP and ALT modes is automatically made being linked with turning of the TIME/DIV switch.) X-Y: The oscilloscope operates in the X-Y mode. The signal to CH1 is used as a signal for X axis (Horizontal axis), and the signal to CH2 is used as a signal for Y axis (vertical axis).

No.	Characters of panel	Explanation
⑬	↑ POSITION PULL 5 × MAG	Vertical position control for CH1. The spot or trace displayed shifts upwards with clockwise turning, and downwards with counterclockwise turning. When knob is pulled out, sensitivity is multiplied by a factor 5.
⑭	VOLTS/DIV	Rotary switch for selection of vertical deflection sensitivity. It covers 5mV/DIV ~ 10V/DIV in 11 ranges. It is adjusted so that the displayed waveform of appropriate amplitude is obtained in the CRT screen.
⑮	VAR ← ▽ CAL'D	Continuously variable gain control for CH1 (or X axis). The sensitivity of each range of the VOLTS/DIV ⑭ is continuously variable. In ▽ CAL'D position, sensitivity is represented by indication of the VOLTS/DIV.
⑯	VAR ← ▽ CAL'D	Continuously variable gain control for CH2 (or Y axis). The sensitivity of each range of the VOLTS/DIV ⑰ is continuously variable. In ▽ CAL'D position, sensitivity is represented by indication of the VOLTS/DIV.
⑰	VOLTS/DIV	Rotary switch for selection of vertical deflection sensitivity. It covers 5mV/DIV ~ 10V/DIV in 11 ranges. Operation is the same method as that of No. ⑭.
⑱	CH1 (X)	Vertical input terminal for CH1. It is also used as input terminal of X axis (Horizontal axis) on X-Y mode. Input signal is connected by using probe (accessory) of BNC connector.
⑲	■ AC ▬ DC	Switch for selection of input coupling method to CH1 (or X axis). In ■ state, input coupling is AC, and in ▬ state, input coupling is DC. On AC coupling, the AC component alone is measured, and on DC coupling, overall input signal including DC component is measured.

782163

No.	Characters of panel	Explanation
⑳	 GND	Switch for connecting CH1 (or X axis) amplifier input to the ground. The input terminal ⑱ is disconnected from the vertical amplifier. It is used for the check of the zero volts level of the trace displayed on the CRT screen.
㉑	CH2 (Y)	Vertical input terminal for CH2. It is also used as input terminal of X axis (Horizontal axis) on the X-Y mode. Input signal is connected by a probe (accessory) or a BNC connector.
㉒	 AC  DC	Switch for selection of input coupling method of CH2 (or Y axis). Operation is the same method as that of No. ⑲ .
㉓	 GND	Switch for connecting CH2 (or Y axis) amplifier input to the ground. Operation is the same method as that of ㉒ .
㉔	EXT TRIG OR HORIZ IN	Common input terminal for external sweep input and external trigger input. When knob 27 is pulled out, the trace is swept on X-axis with the signal of EXT HORIZ IN terminal ㉔ . When triggering switch is set in the EXT () ⑳ position, the displayed waveform is synchronized with the signal of this input terminal.
㉕	TIME/DIV	Rotary switch for selecting horizontal sweep time from 0.5s/DIV to 0.5μs/DIV. The signal measured from DC to high frequency is displayed on the CRT screen with appropriate amplitude.
㉖	VAR←▼CAL'D	Knob for continuously variable adjustment of sweep time. Sweep time of each range of the TIME/DIV ㉕ is continuously variable. (In the CAL'D position, sweep time is represented by indication of the TIME/DIV.)
㉗	LEVEL - ← 0 → + PULL HORIZ IN GAIN VAR.	Knob for adjustment of trigger level in order to keep the displayed signal on the CRT screen stationary, and adjust the start points of traces. Trigger level shifts upwards with turning to direction of → + , and downwards with turning to direction of - ← . When knob is pulled out, the trace is swept on X-axis with the signal of EXT HORIZ IN terminal ㉔ , and knob is for continuously variable adjustment of gain. Maximum gain is obtained by turning clockwise to the end extremely.
㉘ ㉙ ㉚	TRIGGERING  INT AC+  EXT DC-	The triggering switch for selection of trigger source ㉚ , input coupling ㉙ and slope ㉘ . These buttons are set as follows, and used together.

No.	Characters of panel	Explanation
	<p> <input type="checkbox"/> INT (30) </p> <p> <input type="checkbox"/> EXT </p> <p> <input type="checkbox"/> AC <input type="checkbox"/> DC (29) </p> <p> <input type="checkbox"/> + (28) </p> <p> <input type="checkbox"/> - </p>	<p>Displayed signal are used as trigger signals. Selection of trigger signals are linked with setting of the vertical MODE selector as follows.</p> <p> CH1 : Input signal to CH1 is used as a trigger signal. DUAL : Input signal to CH1 is used as a trigger signal. X-Y : — CH2 : Input signal to CH2 is used as a trigger signal. </p> <p>Input signal to the EXT TRIG IN (24) is used as a trigger signal.</p> <p>AC coupling is used for triggering DC coupling is used for triggering</p> <p>When this pushbutton is set in the "+" state, the triggering point is on a positive-going slope of the signal.</p> <p>When this pushbutton is set in the "-" state, the triggering point is on a negative-going slope of the signal.</p>
(31)	<p>  POSITION PULL 5xMAG </p>	<p>Knob for horizontal positioning and 5 times magnifier of horizontal axis. Position of traces shift rightwards with turning clockwise, and leftwards with turning counterclockwise.</p> <p>When the knob is pulled out, sweep time is made 1/5, and then, waveform is multiplied by a factor of 5. (On X-Y mode, although sensitivity of X axis is multiplied by a factor of 5, Noise is increased and frequency bandwise is made narrow.)</p>
(32) (33) (34)	<p>TRIG MODE</p> <p>NORM AUTO TV</p>	<p>Trigger mode selector</p> <p>NORM: When trigger-signal is not applied to the trigger circuit. Circuit is not triggered, trace are extinguished, and the circuit is in stand-by state. It used for a signal below approximately 50 Hz.</p> <p>AUTO: Trace will be displayed even if the circuit is not triggered. Application of input signal, 0 volts level and so on are easily checked.</p> <p>TV : Synchronizing separator circuit is connected to the trigger circuit. The circuit is automatically synchronized to vertical synchronizing signal (TV.V) or horizontal synchronizing signal (TV.H).and the sweep time is the value set by the TIME/DIV (25) .</p> <p>When the circuit is not triggered, the circuit is made free runs.</p>
(40)	<p>TRACE ROTATION</p>	<p>Semi-fixed resistor for adjustment of horizontal incline of traces. Horizontal incline of terrestrial magnetism effects is adjusted.</p>

700165

3.2 Explanation of rear panel (Refer to Fig. 2)

No.	Characters on panel	Explanation
③⑤	—	Power cord with plug.
③⑥	—	Cord winders combined with feet. They are used as feet, when the instrument is vertically stood.
③⑦	Z AXIS INPUT	Input terminals (Binding-posts) for external intensity modulation. This function is used for intensity modulation by external signal or a marker indication by intensity modulation. When no intensity modulation is made, ③⑦ and ③⑧ must be shorted with the short-bar.
③⑧	—	Terminal connected to the chassis (GND). Distance between ③⑧ and ③⑦ is 19mm for the convenience of using it with ③⑦.
③⑨	(Fuse)	Fuse holder. Fuse of 0.5A is used for line voltage of 100V ~ 120V and fuse of 0.3A is used for 220V ~ 240V. The fuse is taken up by turning the cap leftwards.

Note

If X-Y mode pushbutton ⑩ is depressed and also PULL HORIZ IN knob ②⑦ is pulled out at the same time.

The operating mode of oscilloscope is taken precedence by a single trace X-Y mode.

If you want to operate of the EXT HORIZ IN operation with dual trace (CH1 & CH2) operation. You should set the TIME/DIV knob to 0.5S ~ 1mS of the CHOP MODE range.

789168Z

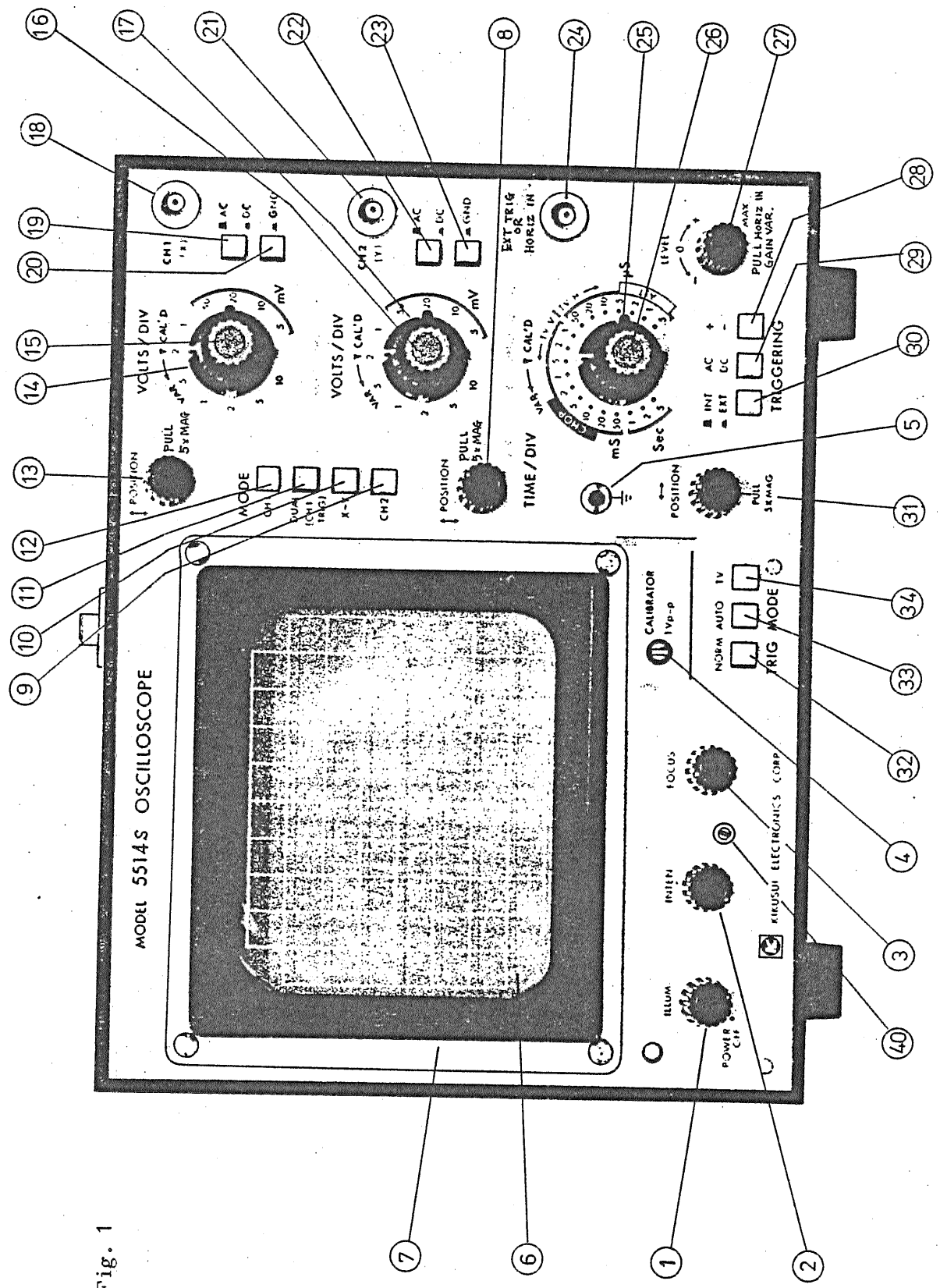

Fig. 1

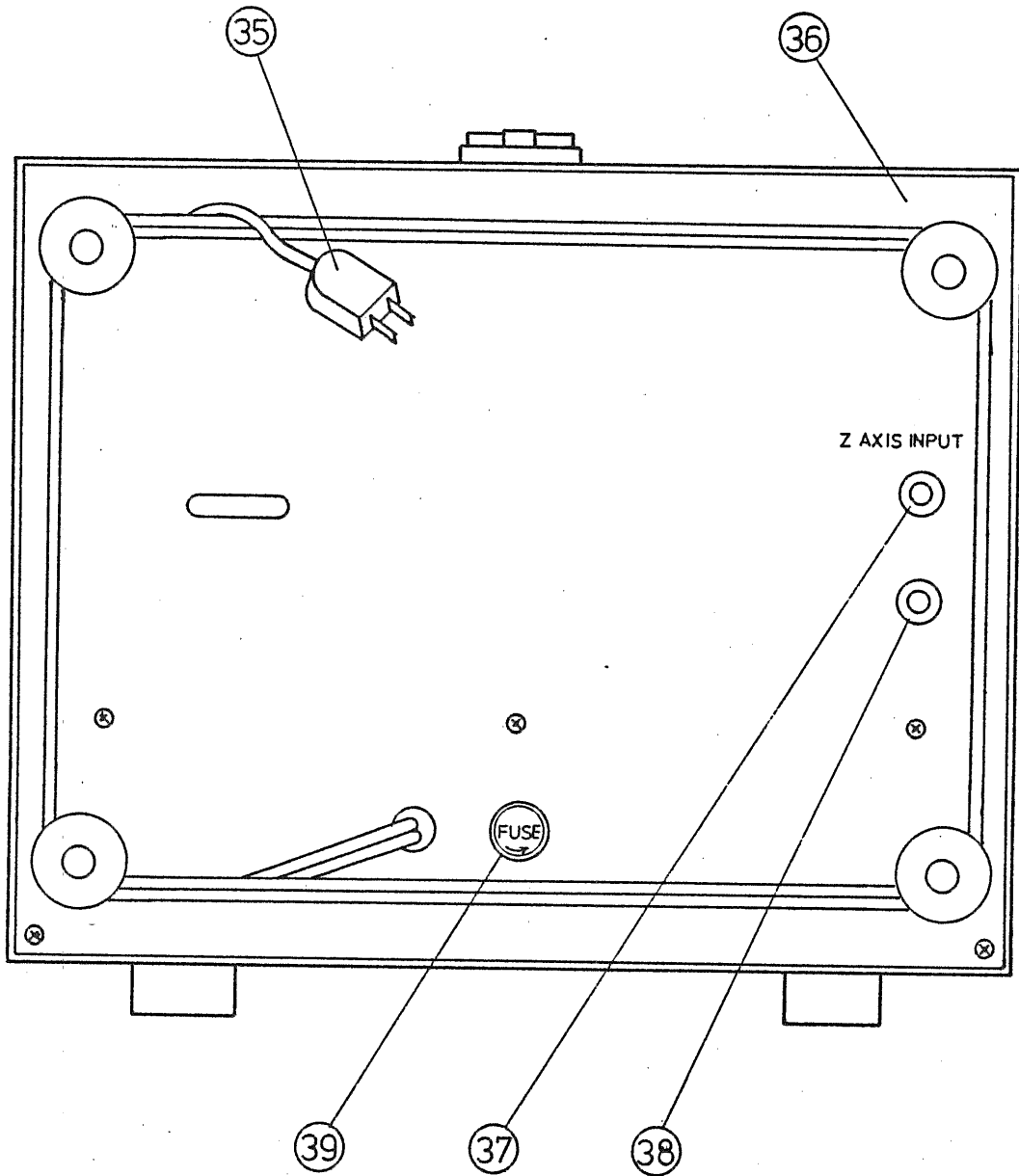

Fig. 2

782168

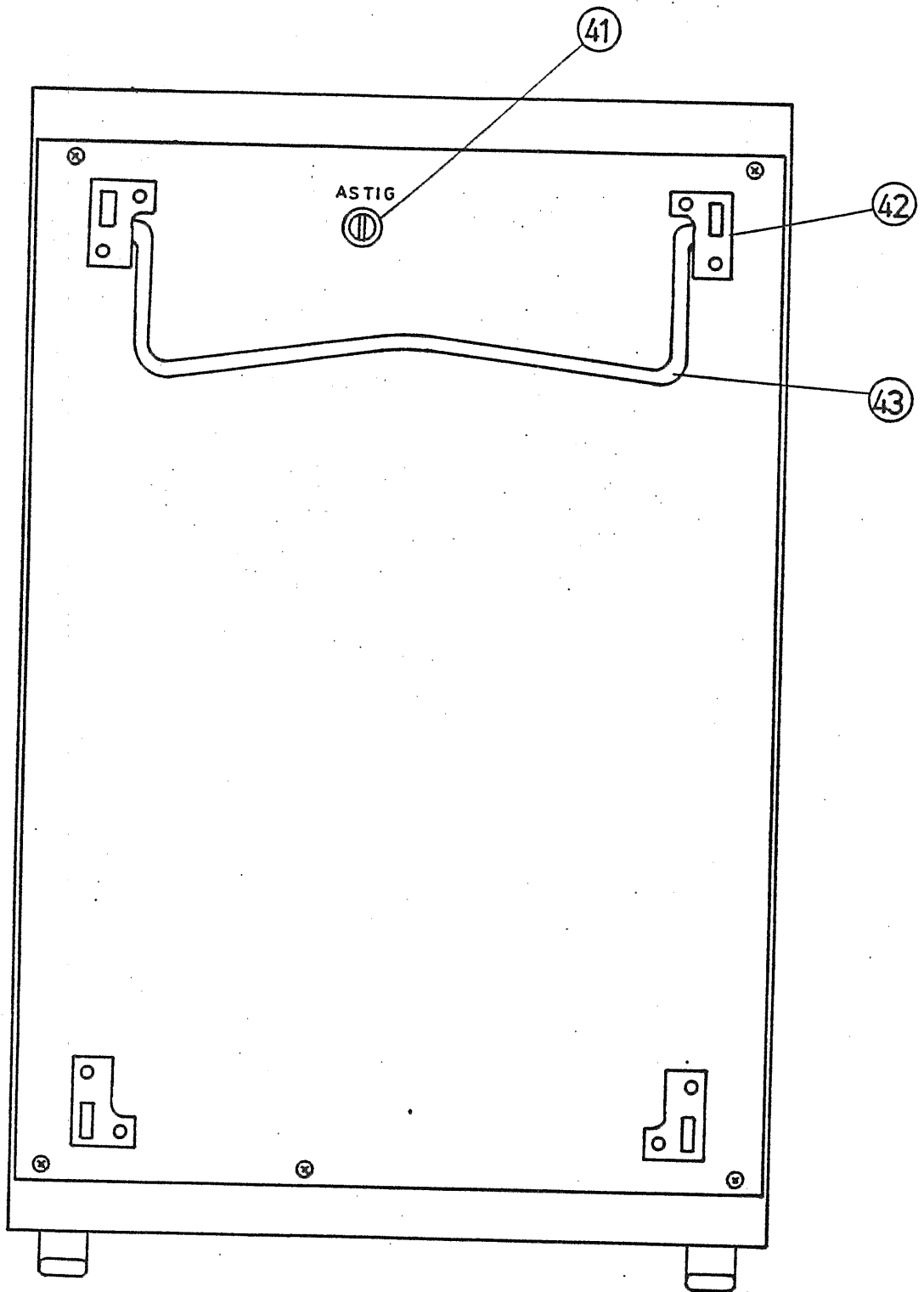

Fig. 3

782169

3.4 Caution of operation

- o Line voltage

The Model 5514S normally operates under the range of $100V \pm 10\%$. If the Model 5514S is operated with line voltage which is not within this range, mal-functioning or damage may result. If the line voltage is not within $100V \pm 10\%$, follow the " Change of line voltage " explained later.

- o Ambient temperature

The ambient temperature range for normal operation of the Model 5514S is $0^{\circ}C \sim 40^{\circ}C$.

- o Environment

If the Model 5514S is operated or is in storage for a long period in high temperature and high humidity, troubles may be caused and the life may be shortened. Strong magnetic field or electromagnetic field also affects adversely the measurement with the oscilloscope.

- o Brightness of CRT

Do not make the trace excessively bright or do not leave a stationary spot for a long period on the CRT screen. The left of the CRT is largely shortened, if such a caution is not made.

- o Allowable maximum input voltage

The allowable maximum voltage of the input terminals and probes supplied as accessories are shown in the below table. Note that oscilloscope may be damaged if a voltage exceeding the specified value is applied.

CH1 and CH2 terminals 5mV, 10mV, 20mV/DIV	400V (DC + ACpeak)
Other ranges	600V (DC + ACpeak)
Probe MODEL 959A BNC	600V (DC + ACpeak)
EXT TRIG IN terminal	100V (DC + ACpeak)
Z AXIS IN terminal	50V (DC + ACpeak)

Note: Frequency is 1kHz or below.

782170

3.5 Change of Line voltage

Taps are provided on the power transformer for operating with a voltage which is not within 100V \pm 10%.

Before operating, make suitable alterations for the voltage used.

(Refer to below table and Fig. 4.)

Voltage of taps	Usable voltage range	Fuse	Remark
100V	90V ~ 110V	0.5A	Plug is used for line voltage 125V. In case of line voltage 125V or more, exchange the plug for the voltage used.
110V	99V ~ 121V		
120V	108V ~ 132V		
220V	198V ~ 242V	0.3A	
230V	207V ~ 253V		
240V	216V ~ 264V		

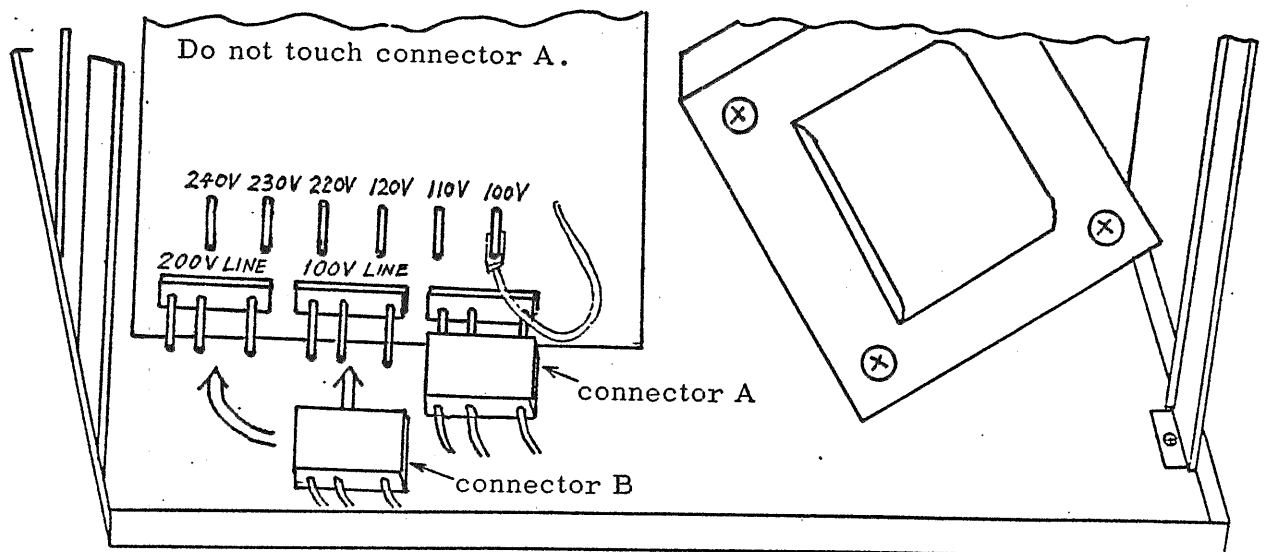

Use by changing taps.

Fig. 4

Note

When line voltage is altered, always take off the plug of the cord from the line voltage source.

Use the suitable plug for the voltage used.

To exchange the capacitor for line filter is not required.

782171

4. OPERATION

4.1 Initial operation (Refer to Fig. 1)

Before turning on the power, set the controls on the front panel as follows.

Characters	No.	Setting
ILLUM (POWER OFF)	①	Extremely counterclockwise position
INTEN	②	Right center
FOCUS	③	Center
MODE	⑨ ⑩ ⑪ ⑫	Depress the CH1 button
↕ POSITION	⑧ ⑬	Center (Depress position knob)
VOLTS/DIV	⑭ ⑰	50mV
VARIABLE	⑮ ⑯	▼CAL'D
AC - DC	⑲ ⑳	■AC
GND	㉑ ㉒	■GND
TIME/DIV	㉕	0.5ms
VARIABLE	㉖	▼CAL'D
TRIGGERING	㉘ ㉙ ㉚	■+ ■AC ■INT
↔ POSITION	㉛	Depressed position
TRIG MODE	㉜ ㉝ ㉞	Depress the AUTO button ㉞

Connect the power cord to an AC line receptacle of correct voltage.

Operate in order of following procedure.

- (1) Turn clockwise the ILLUM control ① from the power off position.
When the power switch clicks, and the power is supplied to the oscilloscope. The LED indicator (Light emitting diode) turns on, where located on the upper left of the knob.
- (2) In some ten seconds later, a trace is displayed on the CRT screen. Adjust the INTEN control ② for appropriate brightness.
If in some 20 seconds later, no trace is displayed adjust the controls again as above table.

782179

- (3) Move the trace to the center of the CRT screen by adjusting the CH1 POSITION (8) and horizontal POSITION (31) controls.
- (4) Adjust the FOCUS control (3) so that a well defined display is obtained.
- (5) Connect a probe to the CH1 input (18) , and to the CALIBRATOR terminal (4) .
- (6) Set the GND button (20) in position, and adjust the LEVEL control (27) so that a stationary is obtained.

A waveform as illustrated below (Fig. 5) is displayed.

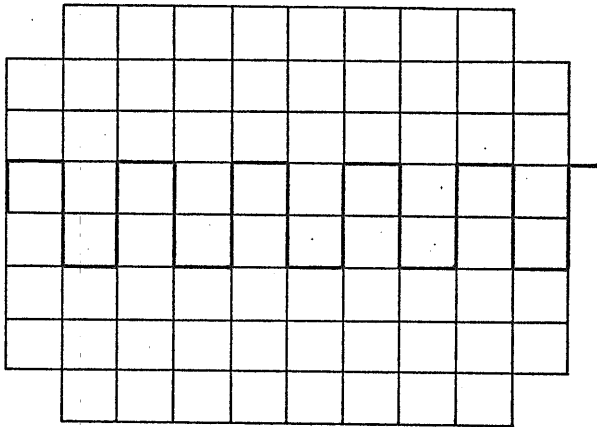

* When the leading edge like the figure is not obtained, phase compensation of the probe is incorrect. Adjust it as " Calibration of probe" .

Fig. 5

- (7) Adjust the VOLTS/DIV (14) and TIME/DIV (25) selectors so that a waveform with appropriate amplitude and cycles for observation is displayed.
- (8) Adjust the ILLUM control (1) so that the graticule lines are illuminated with appropriate brightness.

On above explanation, CH1 only is operated. For operating CH2 only, replace CH1 by CH2 in above explanation.

Dual mode operation and general operations are explained or the following chapter.

1782173

4.2 Dual channel mode operation

Set the MODE selector in the DUAL state (11). Another trace is displayed on the CRT screen. This is a trace by CH2.

(A trace in the preceding articles was one by CH1.)

In the above operating state, the calibration voltage was applied to CH1 but not to CH2. Therefore, a horizontal trace is displayed in addition to the waveform of the calibrator.

Now, apply the calibration voltage to CH2 input terminal (21) also through the probe supplied as accessory, and set the GND button (23) in the position. Two waveforms are displayed by adjusting POSITION controls (8) and (13) as shown in Fig. 6.

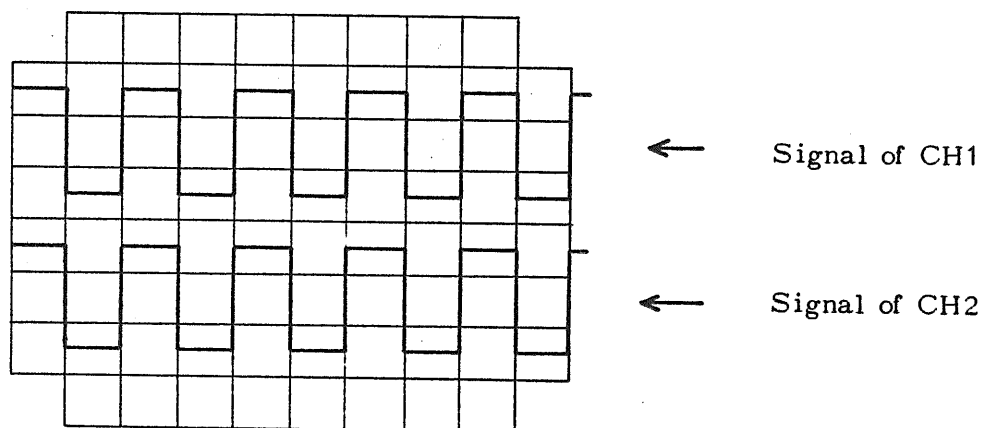

Fig. 6

On dual mode operation, triggering is made with the only signal applied to CH1 (CH1 TRIG). If CH2 signal is synchronized with respect to CH1 signal, both signal are displayed as stationary waveform on the CRT screen.

The Model 5514S has no individual push button for CHOP and ALT modes but has the DUAL button (11) only. In fact, sweep mode selection is linked with the TIME/DIV switch. The sweep circuit operates in the CHOP mode for 1ms or less 1ms/DIV and in the ALT mode for 0.5ms/DIV or more as shown in Fig. 7.

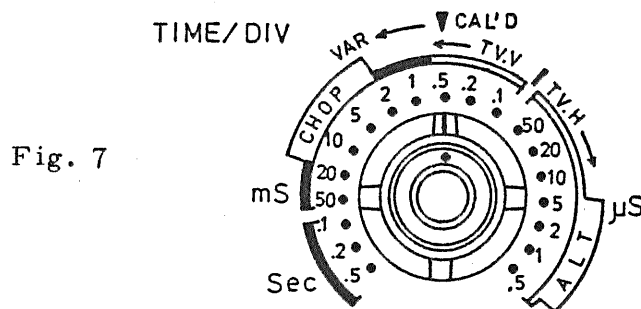

Fig. 7

782174

4.3 X-Y mode operation

Set the MODE SWITCH in the X-Y position ⑩. The Model 5514S operates as a X-Y oscilloscope without another action.

The electrical performance and controllability of the Y axis in this case are the same with that of CH2. That of the X axis, however, becomes such that the frequency range is DC ~ 1MHz for -3dB, and the CH1 POSITION control ⑬ are idle. The horizontal POSITION control ⑳ operates as X axis position control. Other electrical performance and controllability are the same with that of CH1.

Apply the calibration voltage signal to both X and Y axes, and adjust the VOLTS/DIV switches of both channels so that appropriate amplitude is obtained. A Lišsajou's figure by square wave is displayed on the CRT screen as shown in Fig. 8.

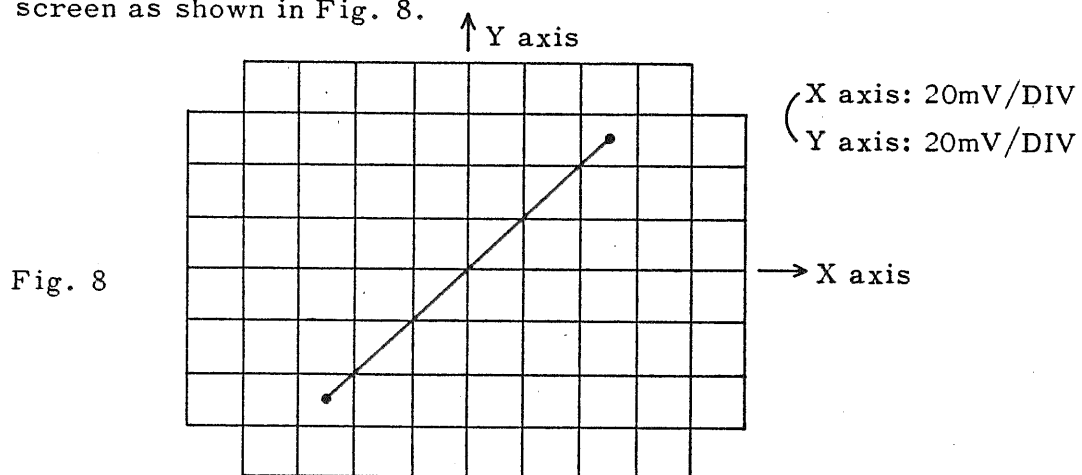

Note On X-Y mode operation, frequency bandwidths of both axes and phase difference between X axis and Y axis must be considered for the high frequency measurement.

4.4 External intensity modulation (INTEN MOD)

This function is used for brightness control by external signal or indicating marker signals by intensity modulation. Remove the short bar of the external intensity modulation terminal Z AXIS INPUT ⑳ (Refer to Fig. 2), and connect a signal for intensity modulation between the terminal ⑳ and the GND terminal ㉑.

When no intensity modulation is made, the two terminals must be connected with the short bar. This function is controlled by a signal of TTL level. Refer to " Caution on operation " for maximum allowable input voltage. Brightness can be controlled with a DC signal.

782175

4.5 Sweep magnification (PULL 5 x MAG)

When a particular section of the input signal is required to be expanded for detailed observation, the requirement may be using a fast speed. However, if the required section is located apart from the starting point of the sweep, the required section may run out of the viewing screen. In such a case, move the required section to the screen center by turning the horizontal POSITION knob and, then, pull out the knob (set in the 5 x MAG state). When this is done, the required section is horizontally expanded by a factor of 5 from the screen center.

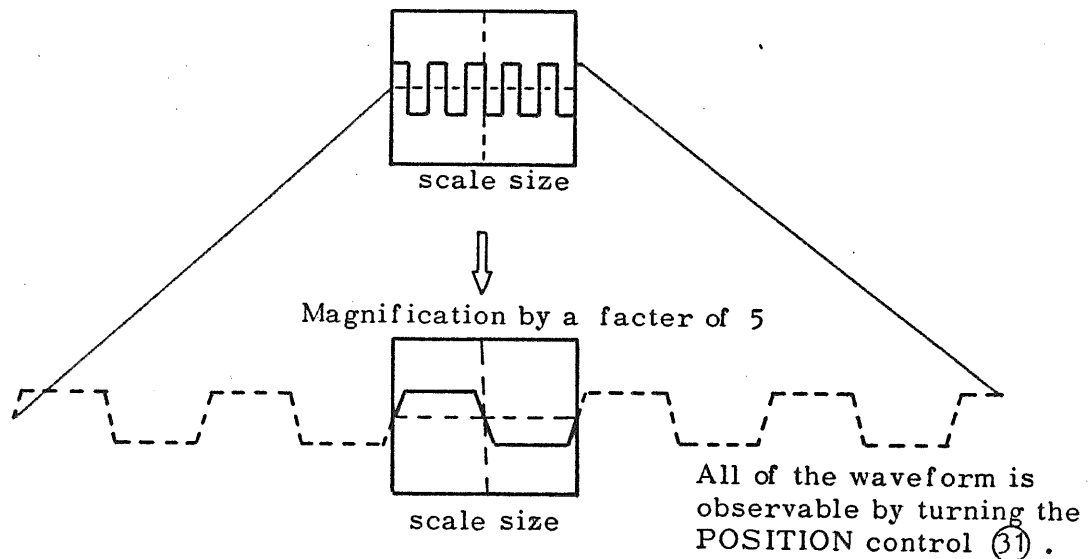

When the 5x MAG function is affected, the sweep time becomes as below.

$$(\text{TIME/DIV indication}) \times 1/5$$

Thus, a sweep speed faster by 5 times than the maximum sweep speed ($0.5 \mu\text{s}/\text{DIV}$) indicated by the TIME/DIV switch is attainable with this function as below. $0.5 \mu\text{s}/\text{DIV} \times 1/5 = 0.1 \mu\text{s}/\text{DIV}$

When the sweep is magnified, the trace intensity is reduced. The use of the sweep magnification should recommendably be limited to the below cases.

- (1) When a particular section which is located apart from the sweep start point is required to be magnified for observation of details.
- (2) When a sweep time of faster than $0.5 \mu\text{s}/\text{DIV}$ is required.

4.6 Operation of the TRIG MODE

- (1) NORM mode : When the amplitude of trigger signal supplied to triggering circuit is an appropriate level for driving the triggering circuit, trigger signal is made from it. Then the sweep circuit is affected, and a stationary waveform is displayed. Such a state is called that the circuit is triggered.

When no trigger input or the low level signal for triggering is applied, the circuit is stand-by state, and no trace is displayed. Such a state is called that the circuit is not triggered. When triggering is not affected, no triggering may be mistaken for incorrect setting of other controls (INTEN ② , \updownarrow POSITION ⑧ or ⑬). The use of the NORM should recommendably be limited to the below cases.

- i) When repetition frequency of trigger input signal is lower than 50Hz.
- ii) When input signal is only applied, waveform is displayed on the CRT screen.

- (2) AUTO mode : The circuit is stably triggered with an input signal of which repetition frequency is more than 50Hz. The sweep circuit free runs automatically even when no trigger input signal is being applied. A bright trace is displayed even at fast sweep ranges and the zero level can be readily checked. For general purposes, use of the AUTO mode is recommended.

- (3) TV mode : This mode is used for observation of television video signal. The only synchronizing signal in the input signal is picked up by synchronizing separator circuit. As the synchronizing signal is used as trigger input signal, the circuit is stably triggered. In $0.5\mu\text{s} \sim 50\mu\text{s}/\text{DIV}$ ranges, the triggering circuit is synchronized by the horizontal synchronizing signal (TV.H) and in $0.1\text{ms}/\text{DIV}$ or less ranges, it is synchronized by the vertical synchronizing signal (TV.V). Select the TRIGGERING +/- position corresponding to the polarity of television video signal measured as Fig. 10.

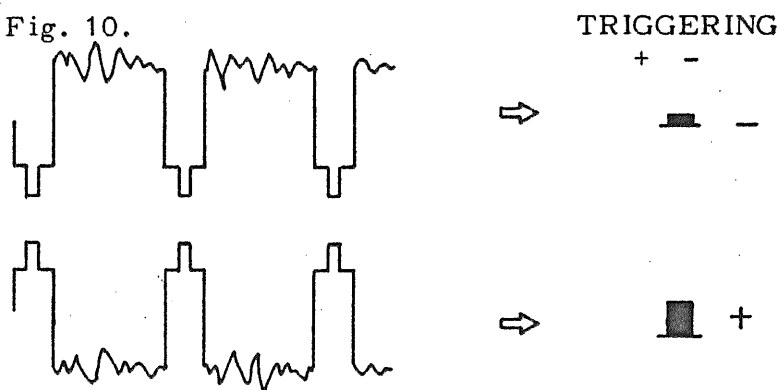

Fig. 10

5. MEASUREMENT

5.1 Application Method of Vertical Input Signal

Vertical input impedance is $1\text{ M}\Omega + 30\text{ pF}$ without probe and $10\text{ M}\Omega + 12\text{ pF}$ with a probe. Connection between signal source and the oscilloscope is made by various method. Covered wires, shielded cable, probe and coaxial cable are used for the connection.

One of these method is selected for following conditions.

Output impedance of signal source

Amplitude and frequency of input signal

Induction from external source

Distance between input signal source and oscilloscope

Connection methods are represented as following table by characteristics of input signal.

Input signal		Connection method		Covered wire	Shielded cable	Coaxial cable	Probe	Others
Low frequency	Low impedance	near		○	○	○	○	
		far			○	○		
	High impedance	near			⊗	⊗	○	
		far				⊗	⊗	
High frequency	Low impedance	near				○	○	
		far				○		
	High impedance	near					⊗	○
		far						

○ : good

⊗ : nealy good

With covered wires: Attach the BNC terminal adaptor (MODEL 942 is supplied as optional accessory) to the vertical input terminal, and connect the covered wires to the adaptor. The input signal can be connected without attenuation. However, measurement under this method may be unstable, because the input wires are susceptible to induction noise interference when they are long or when the input signal source impedance is high, and also the stray capacitance with respect to the ground is large.

As compared with the case the 10:1 probe is used, this method is susceptible to interference with the measured circuit.

With shielded cable: By the use of a shielded cable, external noise introduced in the input connection can be eliminated. However, the use of a shielded cable is disadvantageous in that the capacitance between signal source and ground becomes large (50 pF/m ~ 100 pF/m).

Therefore, the use is not suitable for input connection when the signal source impedance is substantially high or when a signal which include higher frequency components is to be measured.

With coaxial cable: When the signal source impedance is 50Ω or 75Ω.

A coaxial cable of the matched impedance may be used for input signal connection. When an impedance-matched coaxial cable is used, the input signal can be connected without attenuation for high frequency components also. Impedance matching can be connecting a pure resistance (R') of 50Ω or 75Ω corresponding to be characteristic impedance of the cable, in the input side of the oscilloscope as illustrated below.

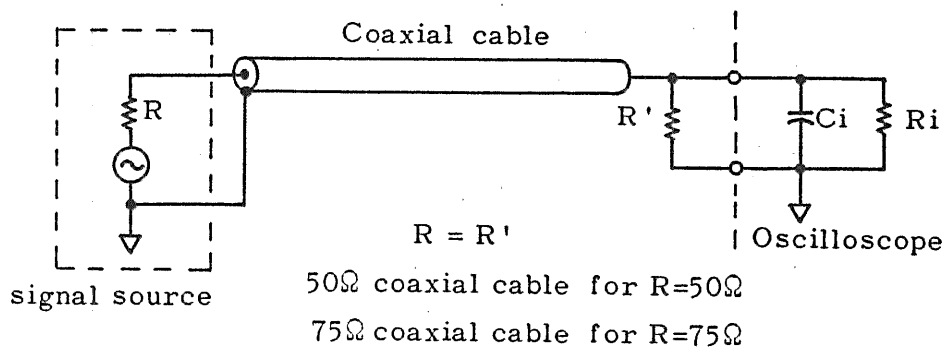

Fig. 11

Use of probe: The 10:1 probe which is supplied as an accessory of the oscilloscope is used. The probe provides electrical shielding from the oscilloscope to the probe and electrical shielding of probe itself for eliminating external noise. As the probe itself makes up a wide-band attenuator with the input impedance of the oscilloscope, the signals measured are connected to the oscilloscope without any distortion of waveforms which include higher frequency components from DC.

A signal is attenuated to 1/10 by using of a probe. However, the loading effect on the measured signal source is reduced, for input impedance is 10 MΩ + approximately 12 pF.

Detail explanations are shown as follows.

782175

Fig. 12

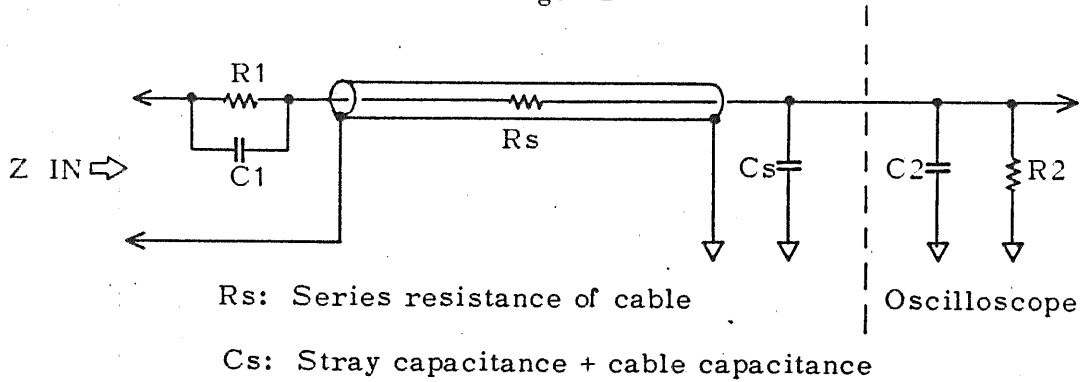

Probe has a resistance R_1 which makes an attenuator with the input resistance R_2 of the oscilloscope and a capacitance C_1 connected in parallel with resistor R_1 which compensates the input capacitance C_2 of the oscilloscope and capacitance C_s of the cable. Such resistances and capacitances make a wide-band attenuator.

Input impedance Z_{IN} are shown as follows.

$$Z_{IN} = \frac{R_1 + R_2}{\omega C (R_1 + R_2) + 1} \quad C = \frac{C_1 \times (C_2 + C_s)}{C_1 + C_2 + C_s}$$

Attenuation ratio A is shown follows.

$$A = \frac{R_2}{R_1 + R_2} \quad \left(= \frac{1M\Omega}{9M\Omega + 1M\Omega} = \frac{1}{10} \right)$$

In case of the probes supplied as accessories, A is represented by the value in ().

Caution

- o The maximum allowable input voltage in page 17 must not be exceeded.
- o The ground wires supplied must be connected. Both of them must be connected also when the oscilloscope is used in the dual channel mode.
- o The phase of the probe must be accurately calibrated. The probe supplied as an accessory of the Model 5514S must be used.
- o The probe must be protected against abnormally large mechanical shock, vibration, bent and pull.
- o The main body and tip of the probe is not highly heat resistant.
Do not make soldering near the probe under the state that the lead wire is being connected to the probe.

782180

5.2 Voltage Measurement

The input coupling selector AC DC button (17) and (22) is set in the AC position, when the AC component alone superimposed on a DC voltage is displayed on the CRT screen. When the signal must be displayed with DC component, the input coupling selector must be set in the DC position. Before measurement, deflection sensitivity is calibrated by setting the variable control (15) and (16) in the CAL'D position. Connect the signal measured to the vertical input terminal, and display a waveform of an appropriate amplitude on the CRT screen by adjusting the VOLTS/DIV (14) and (17). The amplitude is measured by graticule lines. DC component is obtained from the shift value of the trace.

- 1) When a signal is directly applied to the input terminal.

$$\text{Voltage(V)} = \text{Amplitude(DIV)} \times \text{Indication by VOLTS/DIV}$$

- 2) When a 10:1 probe is used

$$\text{Voltage(V)} = \text{Amplitude(DIV)} \times \text{Indication by VOLTS/DIV} \times 10$$

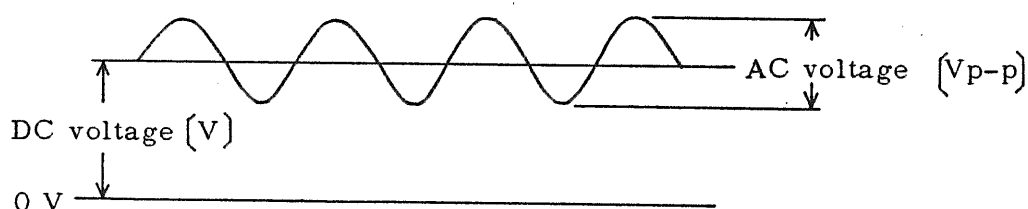

Fig. 13

5.3 Current Measurement (By voltage drop across a resistor)

Connect a resistor R with small resistance so that the current measured follows in it, and measure the voltage drop E across the small resistor by using the oscilloscope. From Ohm's law, current I is represented as below.

$$I = \frac{E}{R} \text{ (A)}$$

Operation of the circuit must be affected by inserting the resistor. Therefore, the resistance as small as possible should be selected. Current up to high frequency from DC can nearly accurately be measured by this method.

5.4 Time Interval Measurement

The time interval between two points on the displayed waveform can be measured by reading value of 'T' referring to the TIME/DIV (25) indication with the variable knob (26) of the TIME/DIV (25) switch turned to the CAL'D position.

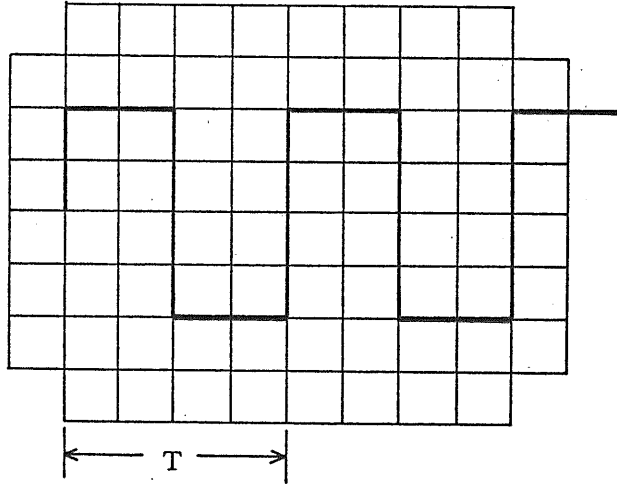

Fig. 14

$$\text{Time } T \text{ sec} = \text{TIME/DIV (sec)} \times \text{Read distance (DIV)}$$

When sweep magnification 5xMAG (31) is affected, time interval becomes 1/5 of the value calculated from above equation.

5.5 Frequency Measurement

- o Frequency is calculated from the period per one cycle of waveform.

Frequency is obtained by measuring the period per one cycle of waveform as follows.

$$\text{Frequency } f \text{ (Hz)} = \frac{1}{\text{Period } T \text{ (sec)}}$$

- o Measurement by Lissajou's figure

The oscilloscope is operated in the X-Y mode with setting the MODE selector in the X-Y (9) (Refer to 4.3 X-Y mode).

A signal with unknown frequency (a measured signal) is connected to X axis, and a signal from signal generator with known frequency is connected to Y axis.

Adjust the appropriate controls so that a figure is displayed all over the screen.

Adjust the frequency of the signal generator so that a stationary waveform is displayed.

782182

Unknown frequency is given by following equation.

$$\text{Unknown frequency (Hz)} = \frac{P_h}{P_v} \times \text{Oscillation frequency of signal generator (Hz)}$$

P_h : The number of points a figure crosses a horizontal line.

P_v : The number of points a figure crosses a vertical line.

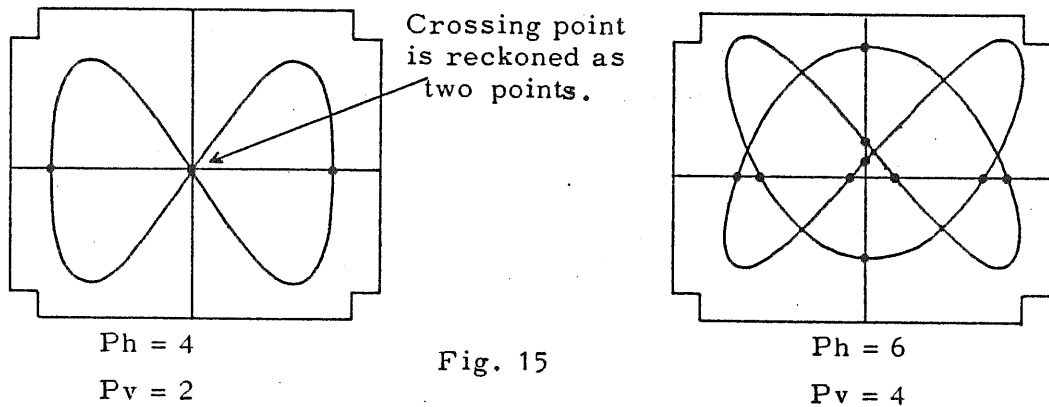

Fig. 15

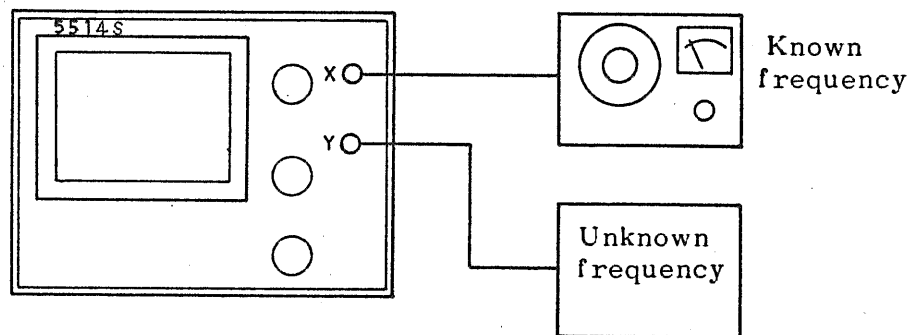

Fig. 16

5.6 Phase difference Measurement

Phase difference measurement with Lissajou's figure

(Refer to Fig. 16, Fig. 17 and Fig. 18)

Operate the oscilloscope in the X-Y mode and display a Lissajou's figure as described in the paragraphs for frequency measurement, by connecting two signals of the same frequency (For example, stereo signal).

Phase difference between two signals is given by following equation.

$$\text{Phase difference } \theta = \sin^{-1} \frac{B}{A}$$

789183

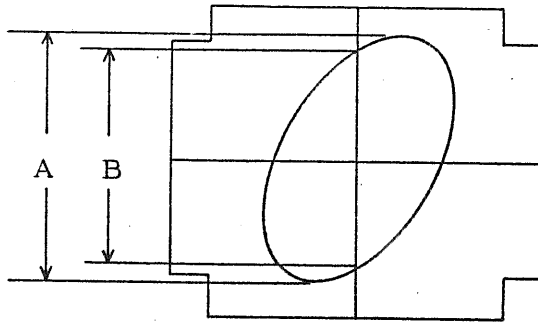

Fig. 17

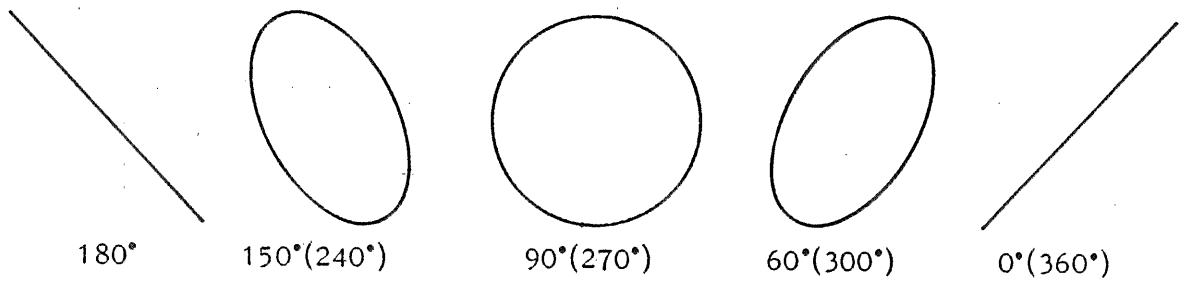

Fig. 18

o Phase Difference Measurement in Dual Channel Mode

Set the MODE selector in the DUAL state, and connect the reference signal to CH1 input and the measured signal to CH2 input each terminals.

Adjust the oscilloscope so that the waveform as illustrated below (Fig. 19) are displayed on the CRT screen.

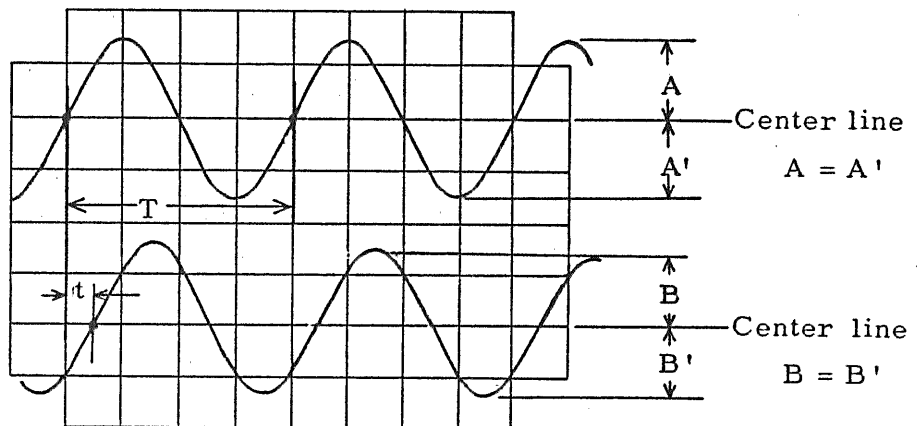

Fig. 19

782184

Phase difference θ is calculated by a below formula.

$$\text{Phase difference } \theta^\circ = \frac{t}{T} \times 360^\circ$$

The dual channel phase measuring method is advantageous in that even very small phase difference (t) can be measured and the leading or lagging state can be known at a glance.

5.7 Pulse Waveform Measurement

Ideal pulse waveform is a square wave which level instantaneously shifts to a certain level in zero time, remains there for a while and instantaneously drops to a basic level without any delay time. Rear pulse waveform is shown in below figure. Names of each parts are defined as follows.

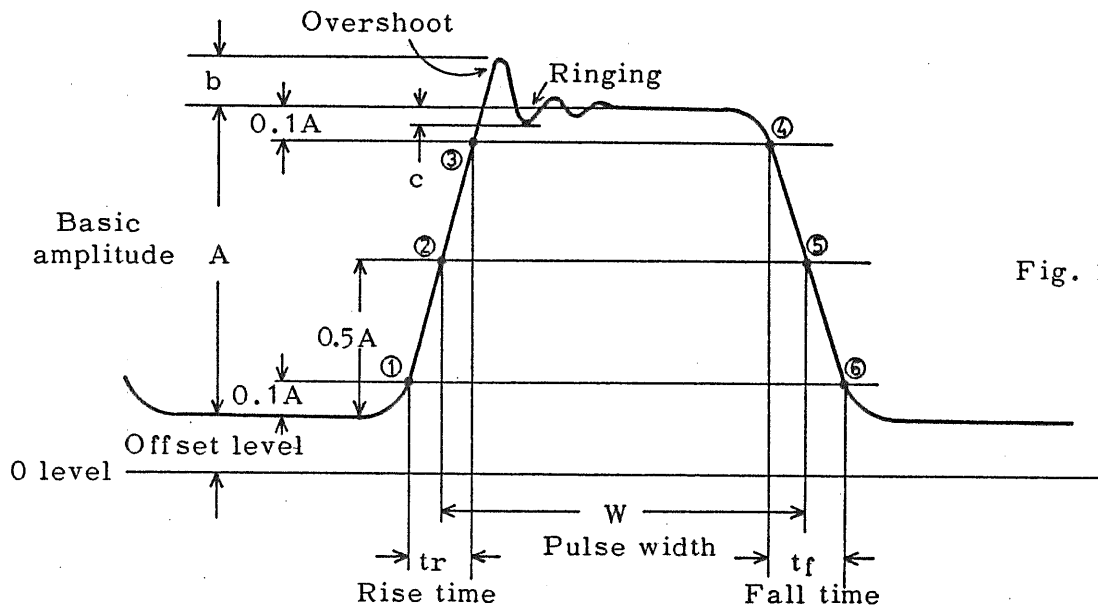

Fig. 20

Pulse amplitude: Basic amplitude A of pulse

Pulse width : The period between ② and ⑤ which are 50% level of basic amplitude.

Rise time : The period between 10% ① and 90% ③ of basic amplitude.

Fall time : The period between 90% ④ and 10% ⑥ of basic amplitude.

Overshoot : On leading edge, a part which level first exceeds the basic amplitude. It is represented by b/A [%].

Ringing : The part which waves after initial rise. It is represented by c/A [%].

782185

c Rise Time Measurement

In a similar manner as " Time Interval Measurement ", rise time is obtained by reading time t_r on the CRT screen. Rise time t_r obtained from the displayed waveform includes that of characteristic of the oscilloscope.

Therefore, when rise time t_n of a pulse measured is near value to rise time t_o of the oscilloscope, the error of the rise time increases.

True rise time is obtained from below formula to eliminate the error.

$$\text{True rise time } t_n = \sqrt{(t_r)^2 - (t_o)^2}$$

t_r : Rise time of the waveform displayed

t_o : Rise time of the oscilloscope (Rise time of the Model5514S is approx. 23.3 ns at 15 MHz.)

For example, the error measured from displayed waveform is approximately 6% for pulse waveform of 100ns rise time which is three times that of the Model 5514S.

o Sag Measurement

The waveform different from that in the preceeding page, may be displayed as Fig. 21. This waveform is caused by attenuation of low frequency component of a waveform, when a pulse waveform passes through an amplifier and so on with poor low frequency characteristic. The inclined part (d) on the figure is called sag. The value of sag is generally represented as bellow equation.

$$\text{Sag} = \frac{d}{A} \text{ (or } \frac{d'}{A'} \text{) } \times 100 \text{ [\%]}$$

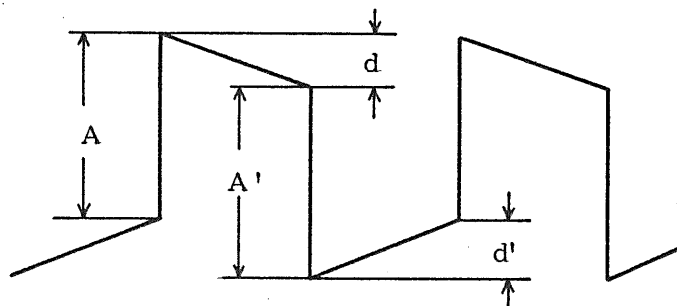

Fig. 21

Note : When the oscilloscope is operated in AC coupling mode, sag is occurred for pulse of low repetition frequency. Pulse waveform of low repetition frequency must always be measured in DC coupling mode.

782186

6. CALIBRATION

6.1 General

The Model 5514S should be calibrated periodically. The calibration should recomendably cover all items. However, calibration on special items may be made instead, for example, the time axis may be calibrated especially carefully if the use of the oscilloscope is primarily for time measurement or the vertical sensitivity may be calibrated with extra attention if the routine measurements require accurate vertical sensitivity.

The overall items must be calibrated after the oscilloscope has been subjected to repair which affects the essential performance of the oscilloscope.

For reliable calibration, please contact Kikusui's agent in your area.

6.2 Check of DC Power Supply and Adjustment of High Voltage Power Supply

Before calibrating the oscilloscope, DC power supplies must be checked, and high voltage power supply (H.V) must be adjusted.

The voltage is shown in below table, and the check points and parts for adjustments are shown in Fig. 22 and Fig. 23.

DC power supply		Point for check and adjustment
+5 V	+4.75V ~ +5.25V	TP-3 -
+12 V	+11.5V ~ +12.5V	TP-1 -
-12 V	-11.5V ~ -12.5V	TP-2 -
+180 V	+170V ~ +190 V	TP-4 -
-1500 V	-1500V \pm 10V	TP-5 (11) HV ADJ

Each voltage must be measured between the check point and the ground.

An accurate digital voltmeter should be used for this calibration.

-1500V DC power supply is for the cathode of the CRT. This voltage must be carefully checked because this largely affects the trace intensity, vertical deflection sensitivity, sweep time and so on.

The voltmeter with very high input impedance (approximately 1000M Ω) must be used for this measurement, because the internal impedance of the high voltage power supply is very high.

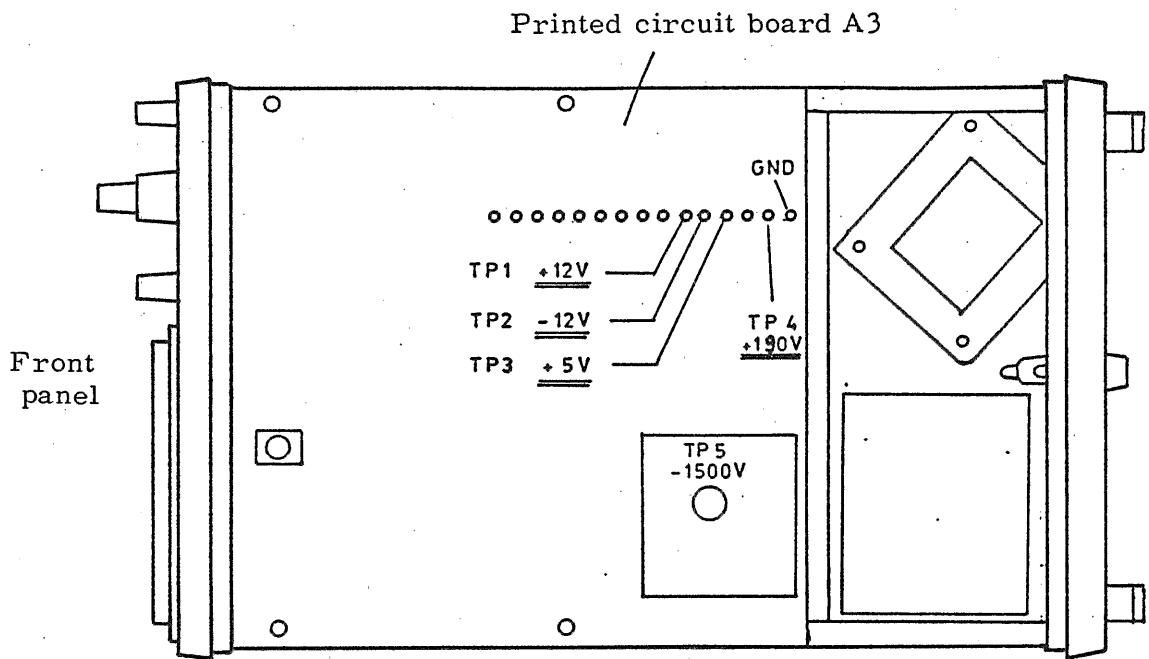

Fig. 22

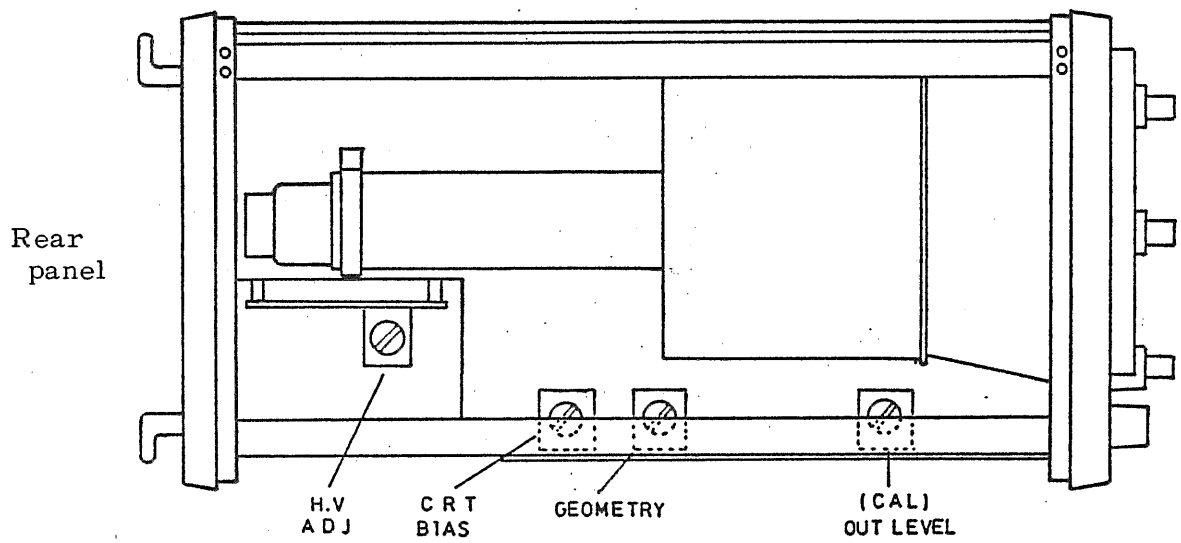

Fig. 23

782188

6.3 Adjustment of Vertical Axes (Refer to Fig. 24.)

o Adjustment of STEP Balance.

This adjustment is made so that the shift of the base trace line caused by switching the VOLTS/DIV switch is made minimum.

- (1) Set the GND button in position, and display a horizontal trace line in the CRT screen.
- (2) Adjust the STEP BAL control (Refer to Fig. 24.) so that the shift of the horizontal trace line is made minimum, when the VOLTS/DIV switch is set in the 5mV range from the 20mV range or in the 20mV range from the 5mV range.

o Adjustment of DC BAL

This adjustment is made so that the shift of the trace line caused by turning the vertical variable knob is made minimum.

- (1) Set POSITION knob in normal position and adjust the horizontal trace line on the center of the graticule line and then pull-out the knob as it is.
- (2) Adjustment of the 5X MAG DC BAL (See Fig. 24.): Adjust the horizontal trace line on the center of the graticule line.

Repeated adjustment for (1) & (2) is to be required.

o Adjustment of DEF LEVEL

- (1) Set VERT MODE in CH1 (or CH2), and display a horizontal trace line in the CRT screen.
- (2) Adjust the DEF LEVEL control (Refer to Fig. 24.) so that the potential of the pin Y of CRT is in 80V.

o Sensitivity Calibration

Vertical deflection sensitivity is calibrated so that the sensitivity corresponds to the value indicated by the VOLTS/DIV. A squarewave generator which has an output voltage accuracy of better than 0.5% and a frequency of 1kHz is used for the adjustment.

- (1) Set the 5mV/DIV of the VOLTS/DIV switch and pull-out the POSITION knob. Add input signal of 8mVp-p from output of the oscillator into the vertical input terminal.
- (2) Set the vertical variable knob to the CAL'D position and adjust the GAIN control at 1mV (See Fig. 24.) so that the waveform which has an amplitude corresponding to the value of 8DIV displayed on the CRT.
- (3) Set the POSITION knob in normal position and Add input signal of 40 mVp-p from output of the oscillator into the vertical input terminal and adjust the GAIN control at 5mV (See Fig. 24.) so that the waveform which has an amplitude corresponding to the value of 8DIV displayed on the CRT.

By above adjustment, sensitivities of the other ranges are calibrated within $\pm 3\%$ of the value indicated by the VOLTS/DIV switch.

- o Input capacitance and phase characteristics compensation of input attenuators
 The VOLTS/DIV switch is composed of 1/10 step attenuator and gain control of preamplifier. Unless the phase characteristics of each range of the VOLTS/DIV switch is correctly adjusted, the waveform displayed on the CRT screen may be distorted and the frequency response may become abnormal. Probe must be adjusted with switching of the VOLTS/DIV switch, when adjustment of input capacitance is incorrect. (Refer to " Use of probe" in Page 25.) A squarewave generator which has a rise time of faster than 1 μ s, little sag, little overshoot must be prepared for this phase characteristics compensation. Adjust the output voltage of the square wave generator so that the amplitude displayed on the CRT screen is 4 DIVs at each range, and adjust the capacitor for phase compensation so that a correct square wave is displayed. Repetition frequency of approximately 1kHz is selected for this measurement. For adjustment of input capacitance, connect a low capacitance C meter to the input terminal, and adjust the capacitor for the input capacitance compensation so that input capacitance at each range is within 30pF \pm 2pF. Capacitors adjusted in each range are shown in following table.

Range	CH1		CH2	
	Adjusted capacitor		Adjusted capacitor	
	Input capacitor	Phase compensation	Input capacitor	Phase compensation
5mV (10, 20mV)	C102	-	C202	-
50mV (0.1, 0.2V)	C104	C105	C204	C205
0.5 V (1, 2 V)	C107	C108	C207	C208
5V (10V)	C110	C111	C210	C211

Characteristics are only checked without any adjustment at ranges in ().

- o High frequency characteristics compensation of vertical amplifier
 This adjustment is made for compensation of frequency characteristics of vertical amplifier by a square wave which has a rise time of better than 10ns and repetition frequency of approximately 100kHz.
 - (1) Set the VOLTS/DIV switch in the 5mV range, and adjust the output voltage of the square wave generator so that the amplitude displayed on the CRT screen is 4 DIVs.
 - (2) Set the TIME/DIV switch in 0.5 μ s range, and adjust the HF COMP. control (Refer to Fig. 24 .) so that the top of the square wave is flat. Frequency characteristics of vertical amplifier is adjusted within 0 \sim 3dB at DC \sim 10MHz.

6.4 Adjustment of Time Axis

Sweep time is calibrated so that the sweep time is the value corresponding to the value indicated by the TIME/DIV switch. Adjustment is made by an accurate 1ms and 10 μ s interval time marker signal or an accurate 1kHz and 100kHz signal.

- (1) Apply the 1ms interval time marker signal or the 1kHz signal to the vertical input terminal, and set the TIME/DIV switch in the 1mS range. Adjust the amplitude of a signal or the VOLTS/DIV switch so that the waveform of an appropriate amplitude is displayed on the CRT screen.
- (2) Adjust the SWEEP CAL control (Refer to Fig. 24.) so that the repetition period of waveform corresponds with vertical graticule lines.
- (3) Apply the 10 μ s interval time marker signal or the 100kHz signal to the vertical input terminal, and set the TIME/DIV switch in the 10 μ S range. Adjust the HS COMP. control (Refer to Fig. 24.) so that repetition period of waveform corresponds with vertical graticule lines. By this adjustment, sweep times of all ranges of the TIME/DIV selector are calibrated, and the function of the 5x MAG is also calibrated by the same adjustment without any other adjustment.

6.5 Adjustment of Horizontal Axis (X axis) (Refer to Fig. 24.)

The sensitivity of X axis on X-Y mode is calibrated by this adjustment.

- (1) Set the output voltage of the oscillator used in item " Deflection Sensitivity Calibration" to 20mVp-p, and apply it to the CH1 (X) input terminal (18) .
- (2) Set the mode selector in the X-Y mode (10) , and set the VOLTS/DIV switch (14) in the 5mV range.
- (3) Adjust the X-GAIN control so that the horizontal trace on the CRT screen is 4 DIVs. By this adjustment, deflection sensitivity of X axis becomes the value corresponding to the value indicated by the VOLTS/DIV switch (14) .

6.6 Adjustment of CRT circuit

o The adjustment of CRT bias

This adjustment is made to obtain appropriate bright trace with respect to the set position of the INTEN knob.

- (1) Set the TIME/DIV switch in the 1mS range, and display a horizontal trace.
- (2) Set white point of the INTEN knob right above, and adjust the CRT BIAS control (Refer to Fig. 23) so that a trace is dimly displayed.

o Compensation of distortion of pattern displayed

Vertical or horizontal trace may bows on the circuit of the CRT screen. This distortion which is called pincushion distortion or barrel distortion is compensated as follows.

Display the rectangular raster on the CRT screen, and adjust the GEOMETRY control (Refer to Fig. 23.) so that correct rectangular pattern is displayed.

Note As the deflection sensitivities are affected by this compensation, all of the adjustments with respect to performance characteristics which are affected by deflection sensitivity must be made again.

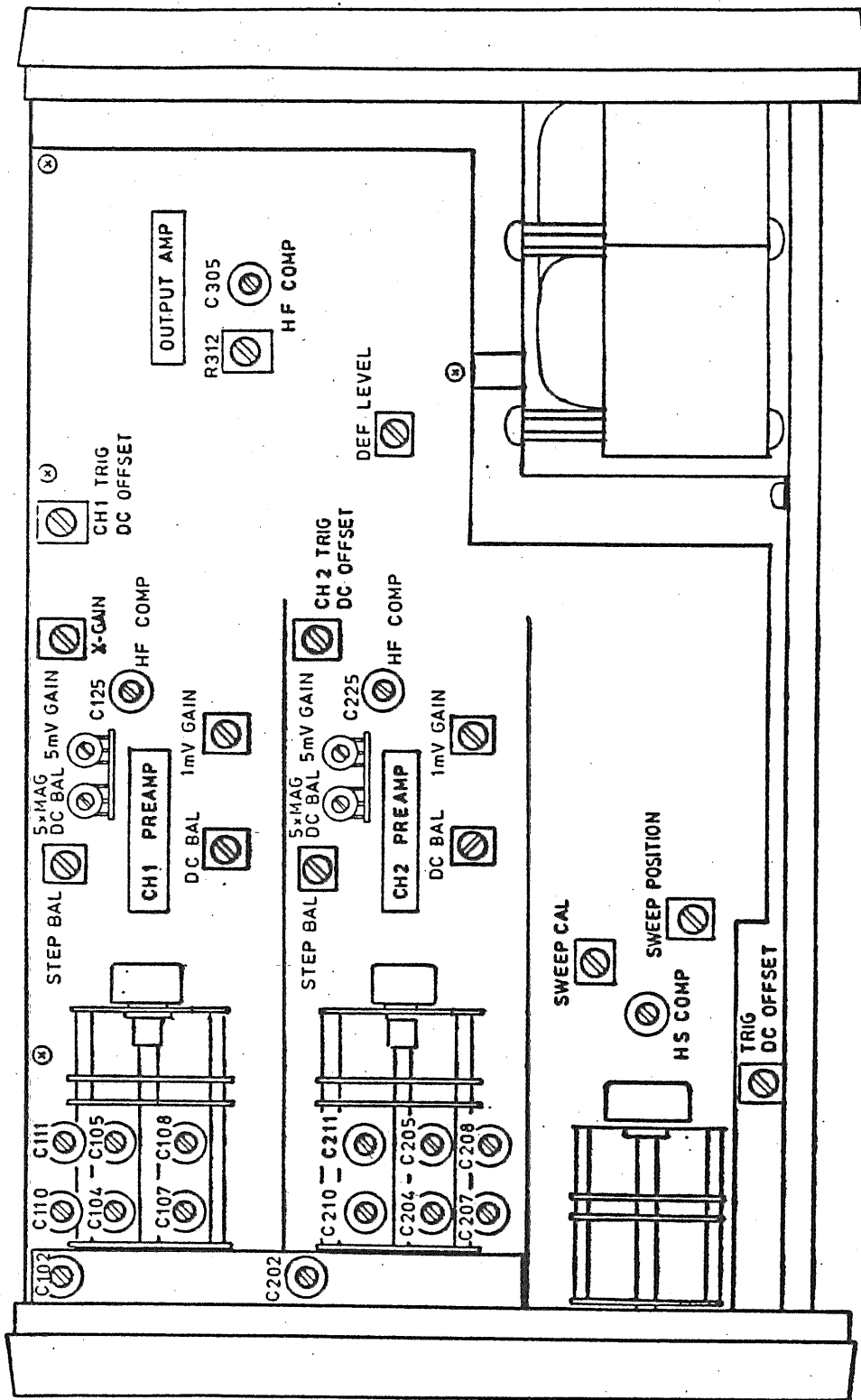

Fig. 24

782192

6.7 Calibration of Probe

Probe is employed as a part of a wide band attenuator, as is explained in "Use of Probe". Unless correct phase compensation is made, the waveform measured is distorted. As the distorted waveform may be realized as a true waveform, probe must correctly be calibrated before measurement. The CALIBRATOR terminal (4) on the front panel is used for calibration.

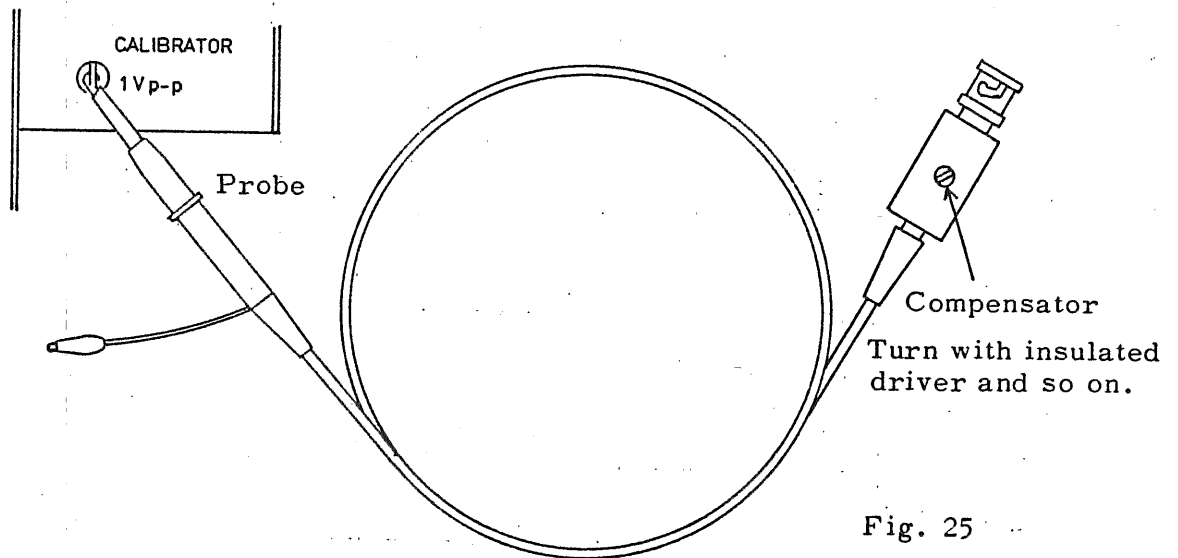

Fig. 25

Connect the probe to the CH1 or CH2 input terminal, and set the VOLTS/DIV switch in the 20mV position.

Connect the tip of the probe to the CALIBRATOR terminal.

Adjust the compensator with insulated driver and so on so that the correct waveform is displayed on the CRT screen as below figure.

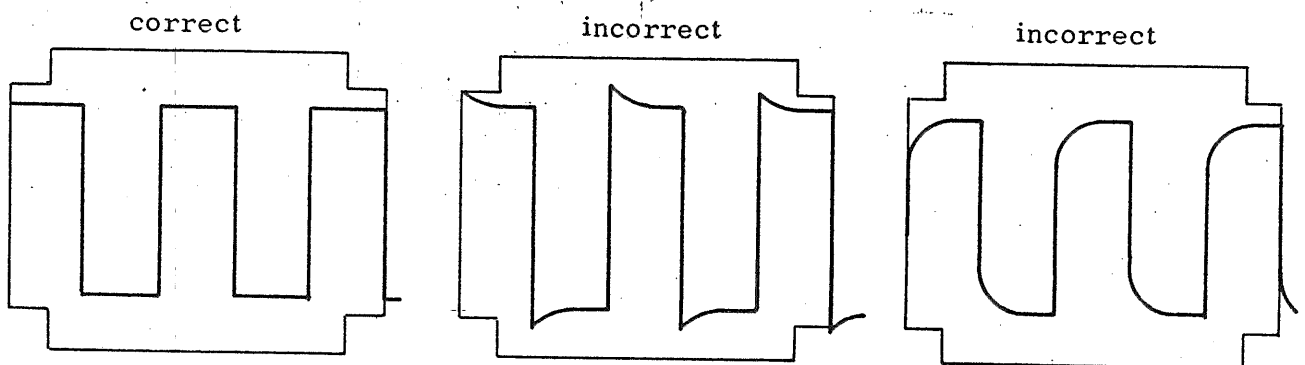

Fig. 26

782193

BLOCK DIAGRAM

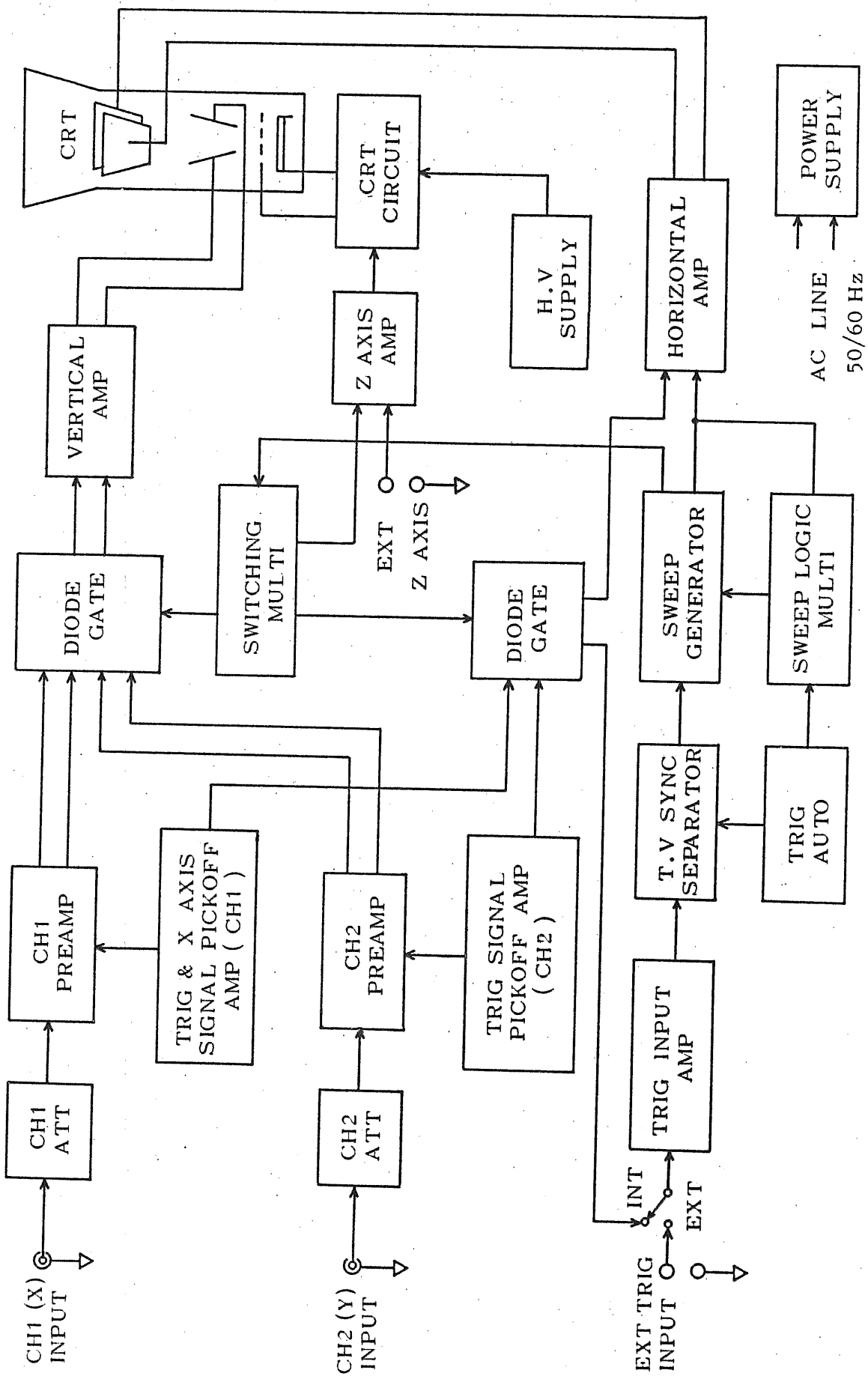

Fig. 25